

LEWIS[®]

dovetailed sheeting

The product

LEWIS[®] sheets are rolled self-supporting "S"-shaped dovetail steel reinforcement sheets which are used for shuttering and reinforcing lightweight concrete floors of limited thickness on timber and light gauge steel floor framing.

Special properties

- * Simple to use because of special rolled profile.
- * Can be laid directly on the floor joists. The t-g timber boards may be omitted resulting in savings on floor height and weight.
- * Fire resistance ratings of 30 and 120 minutes well within range.
- * Airborne and impact sound transmission values according to approved document E of The Building Regulations 2000 achieved without difficulty.
- * Increased strength and rigidity of the inter-connected floor system results in an extra load-bearing capacity up to 30% for the floor as a whole.
- * Water resistant structural flooring.
- * Profile allows air circulation essential for timber preservation.
- * Total floor thickness limited to 50 mm.
- * High load bearing capacity combined with low dead load of 0.9 kN/m².

Reports

A. Sound insulation.

TNO Noise and Vibrations Division reports no. 006.430 and TNO no. 910058
Fraunhofer Institute Stuttgart reports.
TNO "KK Noise Indexes" N.V.A. reports no. 159. 1/1 and 159. 2/1

B. Fire resistance.

Effectis Classification reports in accordance with EN 13501-2:2007.
C.S.T.B. Paris proces-verbal de classement no. RS99-12.

C. Load-bearing capacity.

TNO-Building and Construction Research report no. 2005-BCS-R0399.

D. Inter-connected flooring.

TNO-Building and Construction Research report no. B-88-078/63.6.1219
parts 1 and 2 (adapted).

E. Physical properties

TNO-Building and Construction Research report no. 95-BT-B-0763 CRC/ZTO.

F. Technical Approvals

KOMO (KIWA) Netherlands no. K7470, CSTB France no. 3/09-592,
ATG (Butgb) Belgium no. 2096, BAM Germany no. Z-26.1-36.
SITAC Sweden 0118/07.

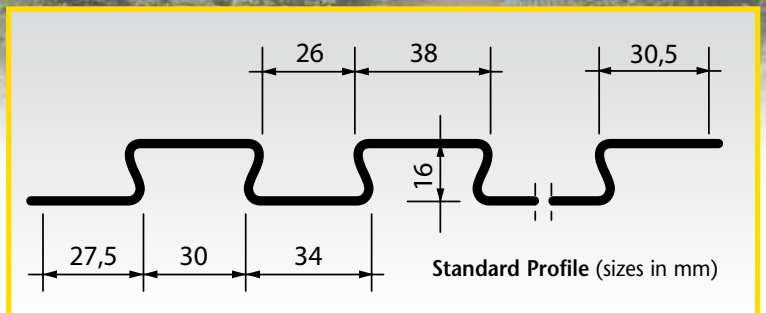

Technical details

nominal width 630 mm
effective width * 580 / 610 mm
standard lengths 1,220 mm

1,530 mm
1,830 mm
2,000 mm
length range 800-7,000 mm

dimensional tolerances: length 1-4 mm
width 1-3 mm

moment of inertia $I_x = 3.6 \text{ cm}^4/\text{m}^1$
moment of resistance $W_x = 3.0 \text{ cm}^3/\text{m}^1$

steel gauge 0.5 mm
height of profile 16 mm
flange width 38/34 mm
weight 0.058 kN/m²

minimum 'fine grade' concrete thickness:
16 mm profile height + 34 = 50 mm. For composition and quality
of concrete see separate application instructions.

* Depends on type of overlap.

Steel quality: S320GD + Z275 N-A-C according to NEN-EN10147

To find out more please contact:

GYVLON
environmental screed solutions

Office - (01925) 428780
Fax - (01925) 428788
Unit 221 Europa Boulevard,
Westbrook,
Warrington,
WA5 7TN.
www.gyvlon.co.uk

Fields of application

- ❑ Sound and fire resistant floors separating compartments.
- ❑ Fire resistant floors for high-risk areas.
- ❑ Water resistant floors/tiled floors on timber in bathrooms, toilets and kitchens.

- ❑ Underfloor heating on timber.
- ❑ Floors having ceramic tiles, terrazzo or flat natural stone as floor coverings.
- ❑ Raised high-stability floors in shops, restaurants and offices.
- ❑ 'Inter-connected structure' for floors with inadequate strength and/or rigidity.
- ❑ Ultra thin concrete floors in steel frame structures.

Method of installation

In our separate leaflet concerning the recommended method of installation, detailed instructions are given regarding laying the sheets, joints, length/width adjustment and voids, method of fixture and the composition and pouring of the concrete. Our technical staff are always willing to answer your questions and give expert advice on any of the various fields of application and appropriate LEWIS® floor systems.

Water resistant floors

In renovation and restoration projects where the existing t+g timber boards and/or joists are to be retained, water resistant floors using LEWIS® sheeting are in the Netherlands traditionally the most appropriate solution for the so-called 'wet areas' such as the bathroom, toilet, kitchen, utility room and changing room. In other words, in any area associated with damp activities.

Ceramic tiles, Terrazzo, Flat natural stone on timber

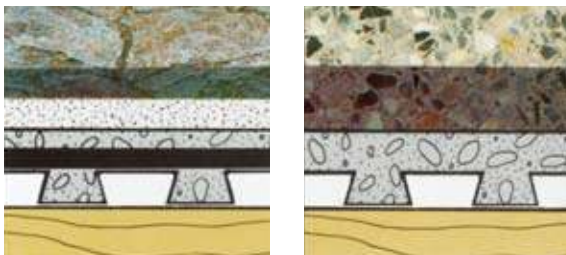

Flat natural stone finish and underfloor heating

Terrazzo finish

The use of LEWIS® sheeting guarantees a durable, stable concrete underfloor. Ceramic tiles and flat natural stone are usually fixed onto the floor using a tile adhesive. Please refer to the standards and regulations currently in force for terrazzo finishes.

Underfloor heating on timber

The usually synthetic piping system is mounted on the upper flute of the LEWIS® sheeting using clips and drill point screws.

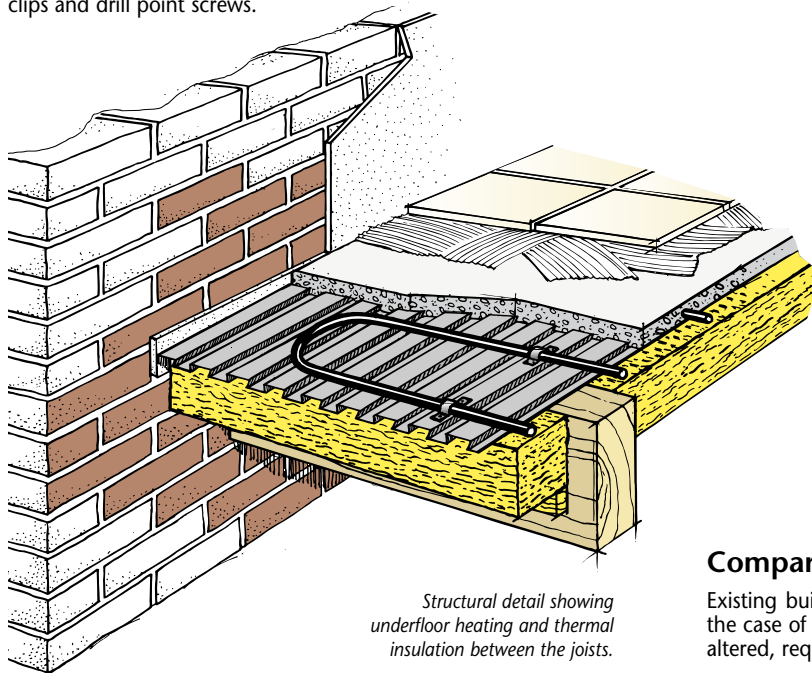

Structural detail showing underfloor heating and thermal insulation between the joists.

A minimum 20 mm of concrete measured from the piping should cover the sheeting. It is important that roughly 10 mm of space is kept free between the perimeter of the concrete floor and the surrounding walls to allow for expansion of the floor.

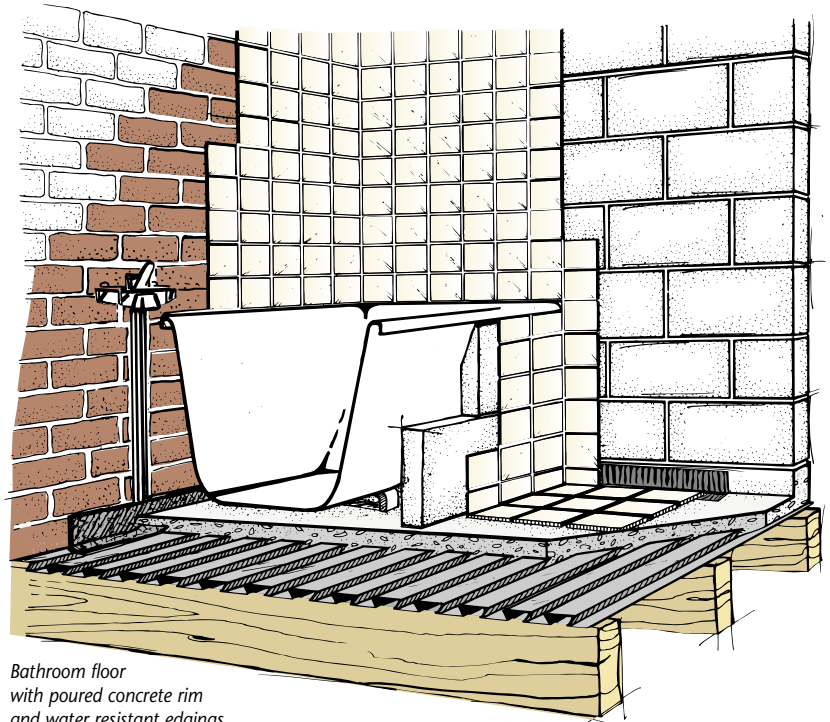

Bathroom floor with poured concrete rim and water resistant edgings joined to new and existing masonry walls

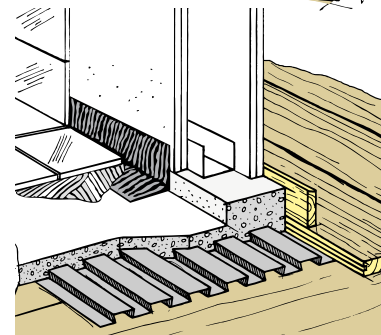

Water resistant edging with poured concrete rim and composite plasterboard compartment wall

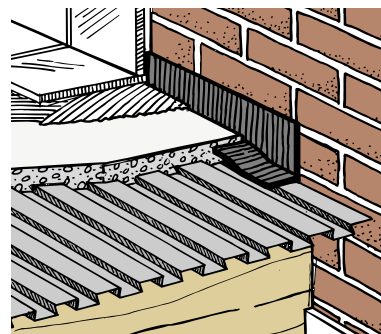

Water resistant edging joined to existing brickwork wall

Compartment floors separating dwellings

Existing buildings often still have sound and therefore usable timber floors. In the case of large-scale maintenance, renovation or when a building's function is altered, requirements in structural design have to be upgraded.

This would be the case when, for instance, floors acquire the function of separating flats in residential buildings. The LEWIS® floating floor construction complies with the requirements for fire resistance, combustibility, airborne and impact sound transmission.

Detailed test reports issued by internationally recognized testing institutes are available for reference.



LWS B0

Composite timber floor structure (joists and t+g timber boards) with plasterboard ceiling and LEWIS® concrete floor on LEWIS® resilient strips placed directly above the line of the supporting floor joist.

Properties

$D_{nT,w} + C_{tr}$ 50 dB
 $L'_{nT,w}$ 49 dB
 $F \geq$ 60 minutes

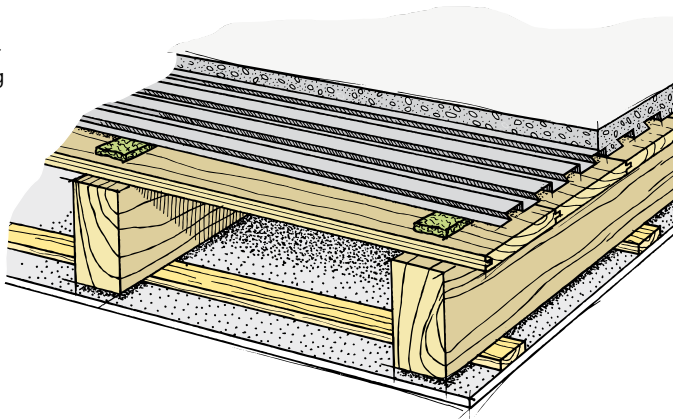

LWS E2

Composite timber floor structure omitting t+g timber boards with decorative ceiling, mineral wool in cavity and LEWIS® concrete floor LEWIS® resilient strips placed directly above the line of the supporting floor joist.

Properties:

$D_{nT,w} + C_{tr}$ 46 dB
 $L'_{nT,w}$ 57 dB
 $F \geq$ 60-90 minutes

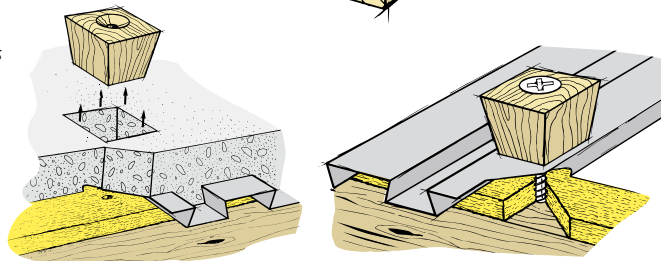
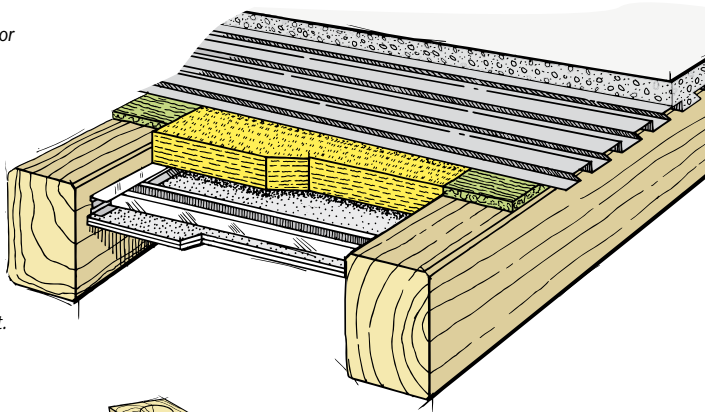

Temporary fixture using wedge-shaped wooden plugs.

Structural design and calculations

Inter-connected floors

The application procedure for inter-connected floors is as follows: In order to prevent initial deflexion resulting from the extra weight of the concrete mortar, the timber joists are temporarily underpinned. After the LEWIS® sheets have been placed at right angles on to the joists with sufficient overlap (see the separate application instructions) they are fastened by a flat head hardened screw nail, type no. 11 dia > 3.4 mm (3.65 mm) length 63.5 mm (2.5"), placed in each lower flute. Next the 'fine grade' concrete mortar is poured in a 30 mm-35 mm layer, measured from the upper flutes of the LEWIS® sheeting. When the concrete has set (after approximately 7 days), the struts can be removed, the floor completed and lightweight partition walls erected.

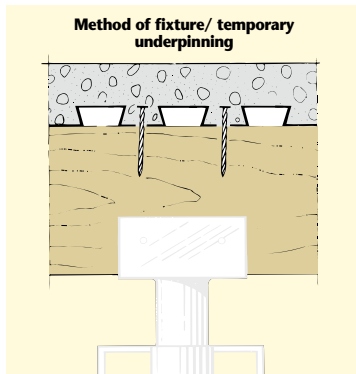

N.B. When lightweight partition walls are put up the imposed load should be increased by $\geq 1.0 \text{ kN/m}^2$ according to BS 6399: Part 1: 1996

According to approved document E of The New Building Regulations 2000 effective as from July 1st, 2003 the requirements for compartment floors separating dwellings are as follows:

Tables 1A and 1B airborne sound $D_{nT,w} + C_{tr} \geq 45$
 impact sound $L'_{nT,w} \leq 62$

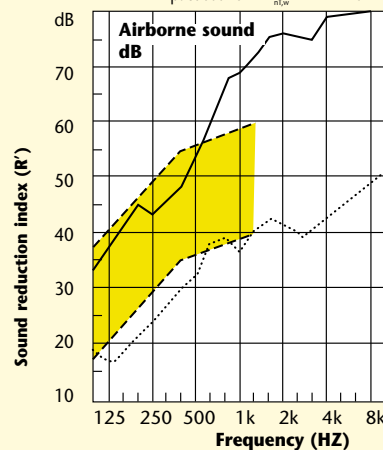

*Airborne sound values

bare wooden floor: $D_{nT,w} + C_{tr} = 30 \text{ dB}$
 insulated floor: $D_{nT,w} + C_{tr} = 50 \text{ dB}$

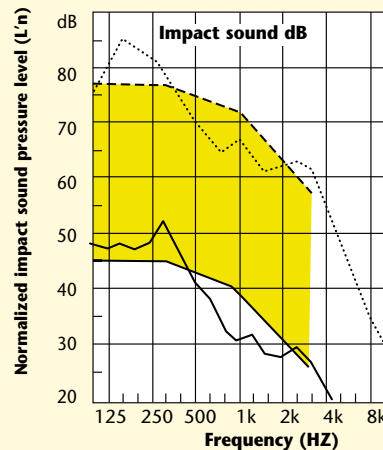

*Impact sound values

bare wooden floor: $L'_{nT,w} = 75 \text{ dB}$ insulated floor: $L'_{nT,w} = 49 \text{ dB}$

Bare wooden floor and plasterboard ceiling
 With LEWIS floating floor construction (LWS B0)
 --- shifted reference curve.

*All values as determined by the TNO Institute of Applied Physics in their Laboratory in Delft. These are only equal to the quantities $D_{nT,w} + C_{tr}$ and $L'_{nT,w}$ as used in field measurements for rooms with a ceiling height of 3 m and a floor space of 10 m².

Non inter-connected floors

A. Timber joists

Maximum clear span in m¹ for timber joists of strength class SC3. The maximum clear span depending on the required allowable load and joist sizes can be read off from the table below.

Table Imposed load not exceeding 1.5 kN/m ² * (dead load more than 0.50 but not more than 1.25 kN/m ²).				
joist sizes in mm	spacing of joists			clear span
	400	450	600	
63 x 150	3.10	2.98	2.63	m ¹
63 x 175	3.61	3.47	3.03	m ¹
75 x 200	4.35	4.19	3.74	m ¹

* Dead load is the load supported by the joist excluding the mass of the joist itself. TRADA publication: "Span tables for solid timber members in floors, ceilings and roofs (excluding tussac rafter roofs) for dwellings applies".

B. Strength analysis for the supporting joist construction according to British Standards

The strength and rigidity of the timber or steel floor framing concerned should always be checked. In the case of simple loads directly supported by the underlying structure the table on this page may be consulted as well as the tables in Approved Document A (Structure) of the Building Regulations 2000. For non-standard structures please refer to the calculation procedures according to the standards and regulations currently in force.

C. Miscellaneous information

Load bearing capacity of completed LEWIS[®] concrete floor
The following tables are intended to give the properties resulting from the combined use of the LEWIS[®] dovetailed profile and 'fine grade' concrete.

1 Allowable variable and concentrated load

Floor thickness in mm	Span in mm	Allowable variable load P _{var} in kN/m ²	Allowable concentrated load F _{rep} in kN
50	600	30.2	3
50	900	19.5	3
50	1200	13.8	3
50	1500	9.7	3
75	2000	6.1	3
75	2500	4.1	3

For higher concentrated loads please refer to TNO report no. 2005-BCS-R0399

2. Required additional reinforcement

Span in mm	Free edge F _{rep} = 3 kN	Floor area F _{rep} = 3 kN
600		
900		
1200	ø 5 - 150	
1500	ø 5 - 150	
2000	ø 5 - 150	ø 5 - 150
2500	ø 5 - 150	ø 5 - 150

3. Load bearing capacity of LEWIS[®] sheets during application without concrete.

clear span (L) in mm	load bearing capacity kN/m ² *(zul-p)	safety factor
600	8.5	1.7
900	5.7	1.7
**1200	3.8	1.7
**1500	2.5	1.7

* values according to DIN 18807, part 3.
Load bearing capacity for statically indeterminate structures including a maximum deflexion of <1/150.
** underpin temporarily until the concrete has set.

4. Minimum concrete thicknesses

standard floor
in domestic housing: 16 + 30 = 46 mm
sound resistant floor: 16 + 34 = 50 mm
inter-connected floor: 16 + 30 = 46 mm
underfloor heating: 16 + *20 + 20 = 56 mm

N.B. profile height LEWIS[®] sheet
16 mm + concrete layer = total thickness of floor.

* assumed diameter of underfloor heating piping.

D. Imposed Floor loads

The minimum imposed floor loads and concentrated loads for buildings are according to BS 6399: Part 1:1996.

E. Dead loads

Dead loads are calculated from the unit weights given in BS 648 (Schedule of weights of building materials) or from the actual known weights of the materials used.

Fire resistant floors

The fire resistance of structural flooring depends greatly on the stability and the load bearing capacity of the timber joists. On the basis of the fire test procedures carried out by the Dutch testing institute TNO and calculations by the Technical University of Braunschweig, Germany, the fire resistance ratings of various LEWIS[®] floor constructions have been determined. To prevent the spread of fire, the "fine grade" concrete mortar should be carefully worked along the floor/wall joints. Penetrations are sealed off with special purpose materials.

Results in minutes according to research by Efectis Delft Netherlands

Fire resistance	
integrity flame resistance thermal insulation (140 C°)	60 - 120

The fire resistance in minutes is mainly due to the cross-sections of the timber joists, the spacing of the joists and the imposed floor load under fire conditions.

Special constructions

Raised floors on various supporting structures

The latter could comprise precast concrete beams, aerated concrete, timber joists or brickwork (See sketch 8). The sheets should be fixed on aerated concrete with drillpoint screws, on masonry and concrete beams with mortar and on timber joists with nails or screws.

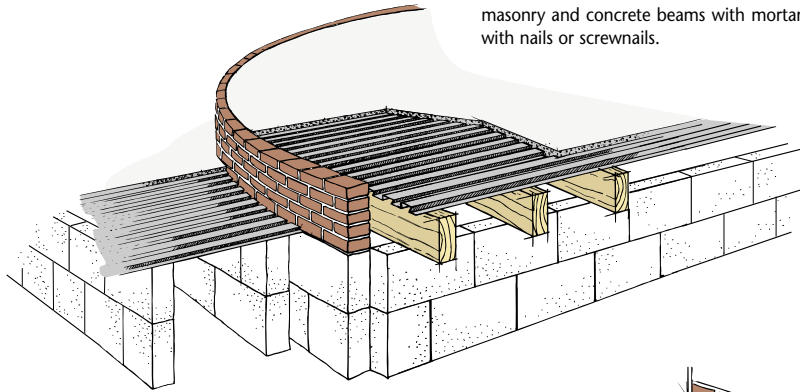

Slanting, uneven floor constructions

Level differences in existing timber floor constructions can be cancelled out by using wedge shaped wooden laths. The final smooth finish can then be achieved by applying a layer of 'fine grade' concrete.

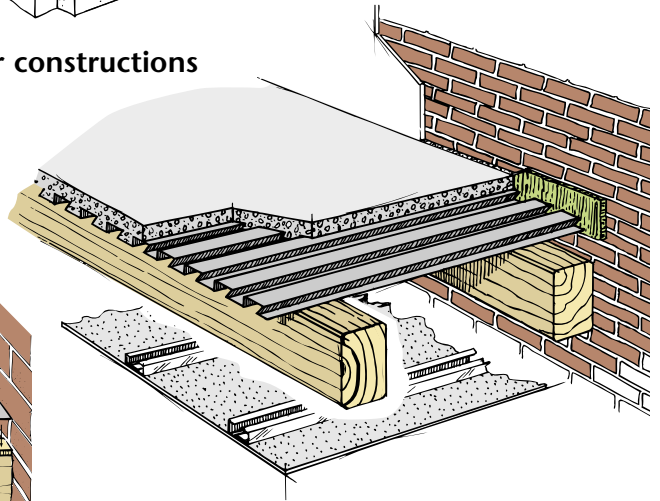
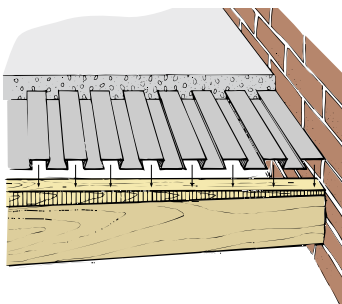

LEWIS[®] concrete floor on timber joists with specially adapted, completely flame and smoke resistant edging connection. Fire resistance rating: F60 - 120 minutes.

(Mezzanine) floors on conventional steel beams or on steel frame supporting structures

The LEWIS[®] sheets are non-interconnected (floating floor system) or fixed onto the underlying steel (frame) load bearing structure with rivets or self-tapping screws. The use of resilient strips is recommended. Studwelding is another manner of fixing.

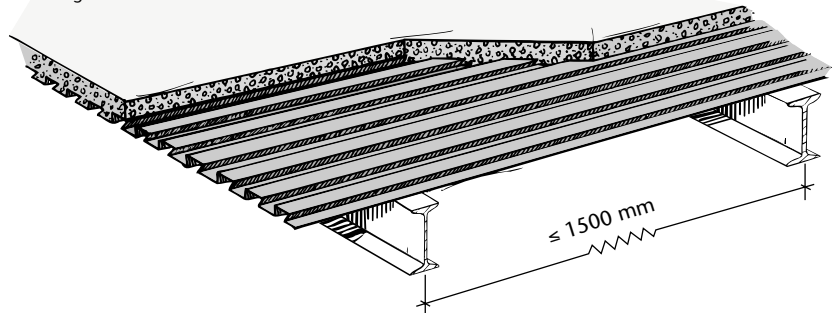

GYVLON

Office - (01925) 428780
Fax - (01925) 428788
Unit 221 Europa Boulevard,
Westbrook,
Warrington,
WA5 7TN.
www.gyylon.co.uk